

Skew Rabbet Plane

U.S. Des. Pat. No. D595,558

Our Veritas® Skew Rabbet Planes, like the Stanley #289 that inspired them, are configured with a full-width blade skewed at a 30° angle that enables the plane to cut right into a corner of a rabbet. This arrangement, along with an adjustable fence and a depth stop, allows them to cut accurate rabbets by hand. A scoring cutter enables cross-grain work by severing the wood fibers ahead of the lapped blade.

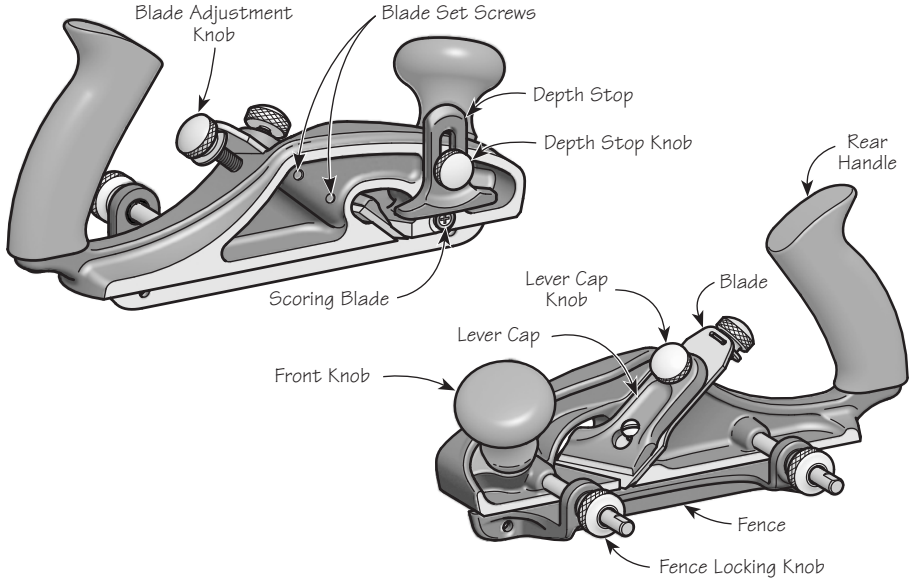

Figure 1: Plane components.

Positioning the Blade

⚠ Caution: Be aware that the blade is sharp; careless handling can result in serious injury.

The position of the blade relative to the plane body is essential to the correct performance of any rabbet plane. The cutting edge needs to be set to the proper projection to achieve the desired depth of cut and needs to be parallel to the sole of the plane. To ensure that it cuts right into the corner of a rabbet, it is critical that the inside (or leading) edge of the blade extend just beyond the side of the plane.

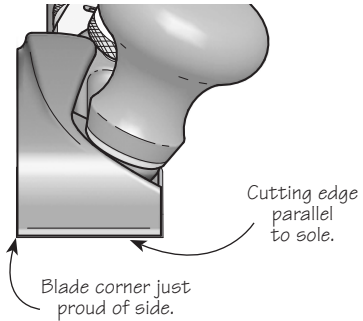

Figure 2: Blade position.

It is equally important that the remaining edge (or side) of the blade behind the leading corner does not extend or angle out farther than the tip, as this would prevent the plane from cutting right into the corner. Note also that, because the blade is skewed, the outer edge of the blade has been bevelled to prevent it from projecting beyond the corner of the blade.

The proper blade position is most easily established using the two blade set screws. First, back off the lever cap knob just enough to free up the blade, and then use your finger to shift the blade over against the set screws. While sighting along the sole of the plane, adjust the set screws until the correct blade position is attained. Once set, the set screws will allow the blade to be removed from the plane and then returned to its previously established position.

Depth of Cut

The depth of cut is the amount of material that is removed with each pass of the plane, typically in the range from 0.005" to 0.020", depending on the hardness of the wood being cut. Adjust the depth as required, tighten the lever cap knob, and take a test cut in a scrap piece of wood to confirm setting.

Cutting Rabbets

The size of the rabet to be cut is controlled by determining the width (A) with the fence setting and the depth (B) with the depth stop setting.

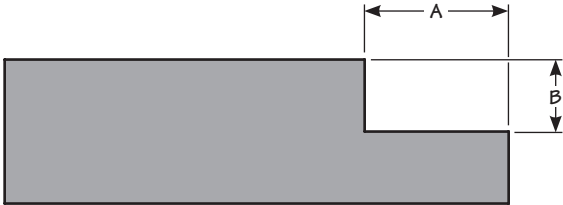

Figure 3: Rabet dimensions.

Setting the Fence

The width of the rabet is determined by the fence setting. Loosen the two fence knobs and slide the fence until the distance from the face of the fence to the outside edge of the blade is equal to the required rabet width. Retighten the fence knobs. Maximum width of 1 1/2" when using the entire blade.

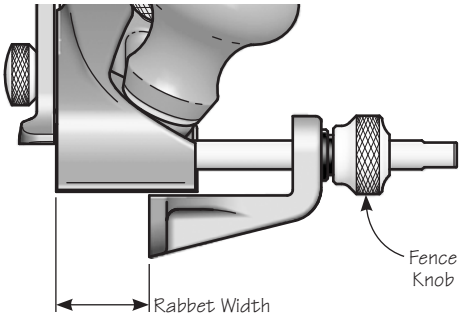

Figure 4: Setting the fence.

Setting the Depth Stop

The depth of the rabbet is determined by the depth stop setting. To set the depth stop, loosen the depth stop knob, slide the depth stop to the desired position, and retighten the knob. Maximum rabbet depth is $\frac{3}{4}$ ". The depth stop and knob can be removed to permit cutting or cleaning up much deeper rabbets, if desired.

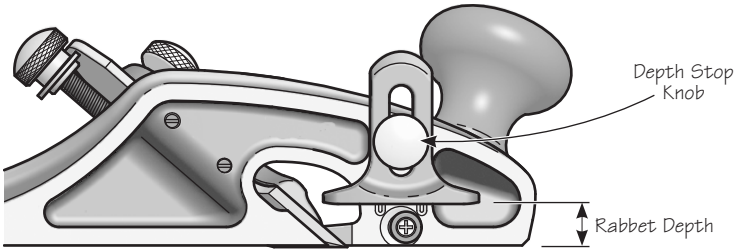

Figure 5: Setting the depth stop.

Setting the Scoring Blade

The scoring blade (or nicker) is used when working across the grain. The circular blade is attached off-center to an axle, allowing the cutting depth to be adjusted by rotating the blade and axle. (It can also be shifted to a neutral position when it is not required.) To rotate the axle, you must first release the locking screw that holds it in position; it is located on the other side of the plane, behind the front knob. Once the scoring blade is in the desired position, retighten the locking screw.

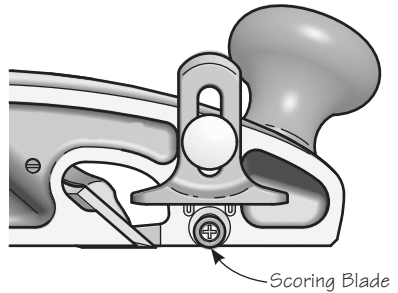

Figure 6: Setting the scoring blade.

The outside (or cutting) edge of the scoring blade must extend just beyond the side of the plane and be aligned with the corner of the blade. To adjust the scoring blade relative to the side of the plane, loosen the fence locking knobs and remove the fence. Unscrew and remove the front fence rod. Loosen the scoring axle locking screw. Insert a small-slot screwdriver through the front fence rod hole to access a slotted set screw that establishes the position of the scoring blade relative to the side of the plane. While pressing the scoring blade and axle in against the set screw, turn the set screw clockwise or counterclockwise, as required until the scoring blade is positioned just proud of the side of the plane. Once the position of the scoring blade is established, retighten the locking screw and reverse the steps to replace the fence rod and fence.

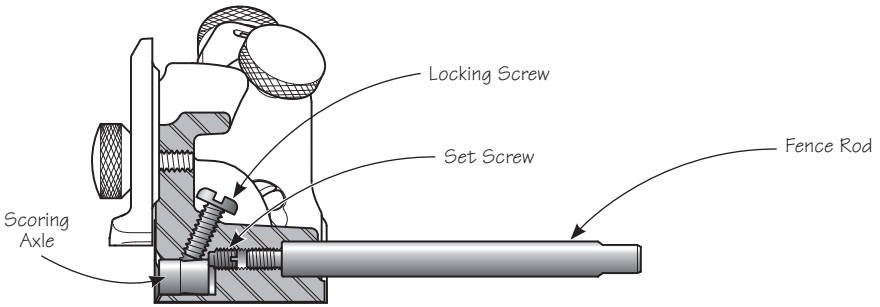

Figure 7: Scoring blade position.

Auxiliary Fence

For cutting some rabbets, such as one where the depth is much greater than its width, you can add a larger auxiliary fence to better register the plane to the workpiece. Simply make a wooden fence, as plain or fancy as you wish, and attach it using wood screws through the holes in the existing fence. Be sure to use screws that are not so long that they break through the working face of the wooden fence.

Blade Sharpening

The skew rabbet plane blade has a 22° skew and is ground with a 30° bevel. The face of the blade is lapped. Additional sharpening need only involve honing a small micro-bevel. Since the blade is installed bevel down, the cutting angle is determined by the bed angle; in this case, 45°.

Note: The Veritas Skew Registration Jig (05M09.03) for use with the Veritas Mk. II Honing Guide (05M09.01) includes a setting for 22°.

When sharpening the cutting edge, it is important to maintain the correct skew angle. Failure to do so may cause the side edge of the blade to angle out farther than the tip, preventing the plane from cutting right into the corner.

The scoring blade will also need to be resharpened over time. Remove the securing screw, then the blade, and lap the face of the scoring blade on a stone.

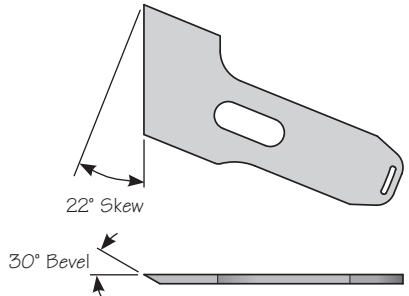

Figure 8: Blade geometry.

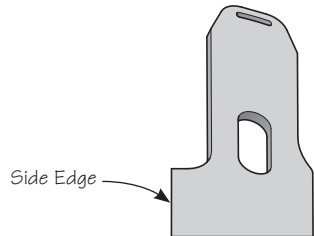

Figure 9: Blade in cutting position.

Care and Maintenance

The body of this plane is ductile cast iron and comes treated with rust preventative. Remove this using a rag dampened with mineral spirits. Clean all machined surfaces.

We recommend that you initially, then periodically, apply a light coat of silicone-free paste wax to seal out moisture and prevent rusting (as well as act as a lubricant for smoother planing). Wipe off any wood dust from the surfaces that you will be waxing, apply a light wax coating, let dry, then buff with a clean soft cloth. At the same time, the solvents in the wax will remove any harmful oils left from your fingers that can lead to corrosion.

Note: Since the face of the fence and the bottom of the depth stop will come in contact with the workpiece, it is important to keep these parts coated with paste wax to prevent marring the workpiece.

If storage conditions are damp or humid, the plane should, in addition to the treatment outlined above, be wrapped in a cloth or stored in a plane sack. This precaution will also guard against dings and scratches.

Accessories

- 05P45.51** A2 Blade, right
- 05P45.52** A2 Blade, left
- 05P45.55** O1 Blade, right
- 05P45.56** O1 Blade, left
- 05P45.71** PM-V11[®] Blade, right
- 05P45.72** PM-V11[®] Blade, left
- 05P45.60** Optional Long Fence Rods, pr.
- 05N35.11** Replacement Scoring Blade